



Summary Report

A summary investigation, in accordance with article 45 of the Ordinance on the Safety Investigation of Transport Incidents (OSITI), was carried out with regards to the following serious incident. This report was prepared to ensure that lessons can be learned from the incident in question.

Aircraft	ERJ 190-100 LR	HB-JVN
Operator	Helvetic Airways AG, 8058 Zurich, Switzerland	
Owner	Bernina Aircraft Leasing Inc. Fort Street 75, 1-1108 Grand Cayman, PO Box 1350, Cayman Islands	
Commander	Swiss citizen, born 1969	
Licence	Airline transport pilot licence aeroplane (ATPL(A)) in accordance with European Aviation Safety Agency (EASA) standards, issued by the Federal Office of Civil Aviation (FOCA)	
Flying hours	total 10 244 hours	during the last 90 days 171 hours
	on the incident type 1085 hours	during the last 90 days 171 hours
Copilot	Swiss citizen, born 1981	
Licence	Commercial pilot licence aeroplane (CPL(A)) in accordance with EASA standards, issued by the FOCA	
Flying hours	total 1123 hours	during the last 90 days 131 hours
	on the incident type 909 hours	during the last 90 days 131 hours
Location	10 km west of Kempten (Germany)	
Coordinates	804 855 / 293 083 (SwissGrid) N 47°45' 22" / E 010°10'18" (WGS 84)	Altitude Flight level 200
Date and time	12 January 2017, 07:33:02 UTC	
Type of operation	Scheduled flight	
Flight rules	Instrument flight rules (IFR)	
Flight phase	Descent	
Type of serious incident	Failure of the cabin air conditioning and pressurization system and the anti-ice system	
Departure point	Vienna (LOWW)	
Destination point	Zurich (LSZH)	
Injuries to persons	Crew	Passengers
Minor injuries	0	0
Uninjured	5	45
Damage to aircraft	Undamaged	
Other damage	None	

Prehistory

The crew assumed control of the Embraer 190 commercial aircraft, registration HB-JVN, on the morning of 12 January 2017 in Vienna (LOWW) for the scheduled flight LX 1585 to Zurich (LSZH). After starting the right-hand engine, the BLEED 2 FAIL message was displayed on the flight deck. This meant that there was no bleed air from the right-hand engine available for the cabin air conditioning and pressurization system and the wing anti-ice system.

The crew processed the steps specified in the relevant emergency and abnormal procedures checklist. As they were unable to resolve the failure, they shut down the engine. After contacting the aviation operator's maintenance company, the crew decided to conduct the flight to Zurich despite the failure. This was possible subject to certain restrictions (see section entitled "Short description of the cabin air conditioning and pressurization system and the anti-ice system").

History of the flight

At 06:24 UTC, HB-JVN left its stand under radio call sign "*Swiss one five eight five*". After the aircraft was de-iced, it took off from Runway 29 at Vienna Airport at 06:48 UTC. On board were 2 pilots, 3 cabin crew members and 45 passengers. The copilot was pilot flying (PF) and the commander was pilot monitoring (PM) for the whole duration of the flight.

The auxiliary power unit (APU) was running at take-off. During this period, the engine 1 provided the cabin air conditioning and pressurization system with bleed air. The recordings show, that from lift off up to an altitude of around 3000 ft, both air conditioning packs were switched off and the anti-ice system was active. Three minutes after take-off, the crew shut down the APU. The only remaining available bleed air source was therefore the left engine.

Cruising took place at flight level (FL) 300 and was uneventful. During the descent into Zurich, the aircraft was flying in icing conditions. At 07:30:29 UTC, the aircraft ice detectors indicated ice formation and the anti-ice system was switched back on. At the same time, PACK 2 was automatically switched off, which surprised the flight crew. At 07:31:25 UTC the ice detectors ceased indicating ice formation.

At 07:33:02 UTC, the BLEED 1 LEAK message was displayed on the flight deck and the engine bleed air from the left engine was automatically switched off. As a result, the cabin air conditioning and pressurization system and the wing anti-ice system failed. The aircraft was at FL 200. The commander decided to descend faster. To this effect, he transmitted the urgency message "*Pan Pan*" and requested clearance to descend. At the same time, the ice detectors indicated renewed ice formation. Air traffic control immediately issued clearance to descend to FL 130.

At 07:33:34 UTC, the commander started the APU. Seconds later, the A-I WING FAIL message was displayed on the flight deck, which made it clear to the flight crew that the anti-ice system was no longer available. At 07:34:07 UTC the APU FAIL message was also displayed, because the APU had not started. The commander requested immediate clearance to descend below FL 100 and immediately received clearance for FL 90. Between 07:34:09 UTC and landing, the ice detectors did not identify any further ice formation.

The commander then decided to declare an emergency. At 07:34:44 UTC, he transmitted the emergency message "*Mayday*" and informed air traffic control of his situation. Air traffic control issued clearance to descend to FL 60. At 07:35:58 UTC, the commander read a cabin pressure altitude of 4800 ft at an altitude of around 10 000 ft AMSL¹. At 07:36:24 UTC, he informed the cabin crew and told them to expect a normal landing in 20 minutes.

¹ AMSL: above mean sea level

At 07:41:13 UTC, the commander began to process the BLEED 1 LEAK checklist. The flight crew rejected air traffic control's offer of the shortest possible approach on Runway 28 at Zurich, because they no longer expected icing conditions. At 07:44:49 UTC, the commander began to process the A-I WING FAIL checklist. A second attempt to start the APU was then successful.

Air traffic control guided the aircraft onto the instrument landing system (ILS) for Runway 14 using radar vectoring. The approach was uneventful. The flight crew adopted a higher approach speed than normal in order to deal with any residual ice on the wings. At 07:57:06 UTC, the aircraft touched down on Runway 14 and taxied to the allocated stand. The passengers and flight crew disembarked the aircraft normally.

Short description of the cabin air conditioning and pressurization system and the anti-ice system

The air conditioning and pressurization system supplies the cabin and flight deck with conditioned air. This air is provided by the two engines or the auxiliary power unit (APU) in the form of bleed air. The engine bleed air is fed from the 5th-stage (low-pressure – LP) and the 9th-stage (high-pressure – HP) (see Figure 1). The temperature of this bleed air is regulated in the pre-cooler using fan air before it is conditioned using the two air conditioning packs (PACK). Normally, PACK 1 is supplied by the left engine, and PACK 2 is supplied by the right engine.

The APU bleed air can be used to supply both PACKs both on the ground and in the air. The APU can ensure air conditioning and pressurization up to FL 150. Normally, however, the APU bleed air is used to supply both PACKs on the ground and to start the engines. The APU bleed air cannot be used for the anti-ice system.

It is not possible to use the engine bleed air and the APU bleed air at the same time. If both sources are available, the air management system (AMS) ensures that only one bleed air source is activated.

The bleed air from the two engines is also used to anti-ice the engine (ENGINE ANTI-ICE) and wings (WING ANTI-ICE). Engine anti-icing takes place directly using the 5th-stage LP bleed air, while wing anti-icing² uses a blend of 5th-stage LP bleed air and 9th-stage HP bleed air. The bleed air is fed to the wing anti-icing ducts via the engine bleed valve, the pre-cooler and the wing anti-ice valve (WAIV) (see Figure 1).

The bleed air ducts (engine bleed, air conditioning ducts, APU bleed air distribution and anti-ice ducting) are generally monitored by an overheat detection system (ODS). The ODS is equipped with overheat detection sensors. If hot bleed air escapes as the result of a leak, the sensors respond and automatically close the corresponding engine bleed valve. This is displayed to the flight crew on the flight deck by the red BLEED 1(2)³ LEAK warning message.

Engine and wing anti-icing takes place automatically during normal flight operations. Ice detectors are mounted on the right and left side of the aircraft nose. If these ice detectors indicate ice formation, the corresponding wing and engine anti-ice valves are opened automatically and remain open for five minutes after ice formation ceases to be indicated. The blue ICE CONDITION advisory message is also displayed to the flight crew. If, as in the present case, the bleed air supply fails completely, the two WAIVs close automatically and the amber A-I WING FAIL caution message is illuminated on the flight deck. The engine anti-ice is not affected by this, as it is supplied directly by using 5th-stage LP bleed air and independent of the engine bleed valve position.

² Wing anti-icing is performed via ducts on the inside of the leading edge of the wing. There is also a duct manifold for heating the engine pylon.

³ The number 1 refers to the left engine, while the number 2 refers to the right engine.

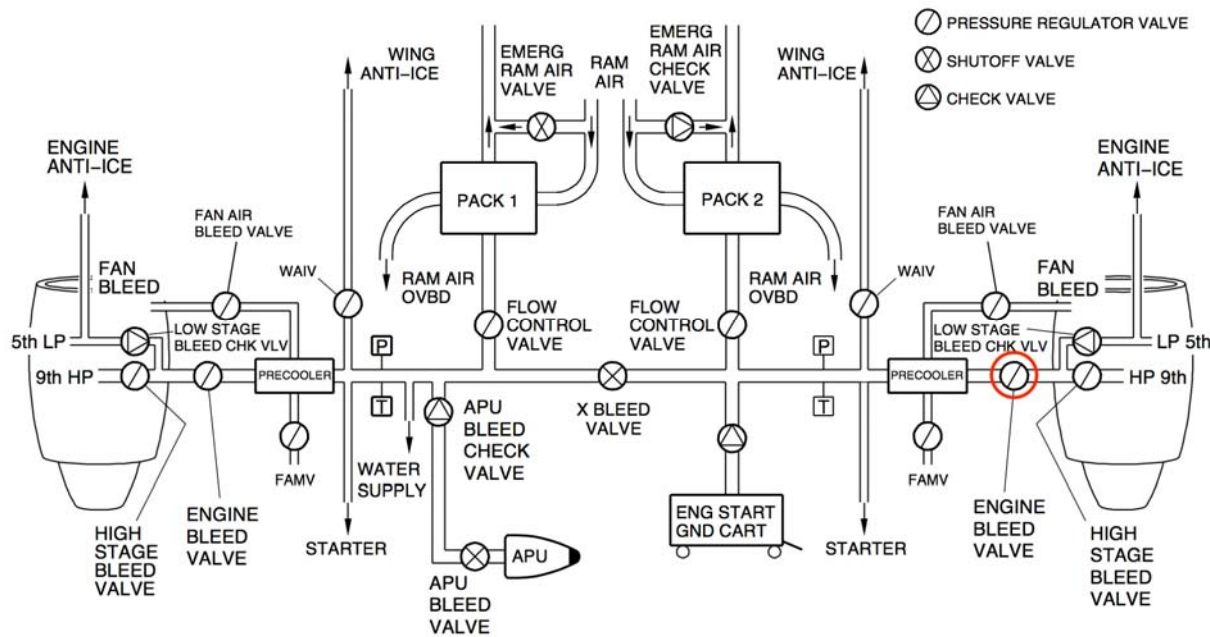

Figure 1: Schematic representation of the bleed air system. The right engine pressure regulator valve (engine bleed valve) is circled in red. Source: aircraft manufacturer's AOM⁴.

If one engine bleed air fails, the amber BLEED 1(2) FAIL caution message is illuminated on the flight deck and the relevant consumer can be supplied with bleed air from the other engine via the crossfeed (X BLEED VALVE). If one engine bleed air is not available before the flight, according to the MEL⁵ (chapter 36-00-00), it is still possible to conduct the flight using only a single bleed air source.

According to the MEL, cruising altitude is limited to FL 310 in the case of operation with only one engine bleed system. The following information for flight crews is published in the MEL: *"The first dispatch condition on MEL [corresponding to the present case] has no icing condition restrictions, since the Cross Bleed Valve operates normally."* It also contains the following information regarding descent: *"Engine in-flight idle thrust increases significantly when one Engine Bleed is inoperative. Plan for an earlier descent or use speed brakes to reduce speed appropriately."*

Additional information

In the past, several incidents occurred which suggested a sensor failure in the overheat detection system (ODS). For this reason, the aircraft manufacturer published Service Bulletin (SB) no. 190-36-0019, dated 31 August 2012. The aircraft manufacturer's reason for the SB was as follows: *"Embraer engineering analysis revealed that the ODS sensors located at the pylon are being degraded and presenting failures due to the high level of vibration present on the region."*

The purpose of the SB was to move the ODS sensors in the engine pylon, to secure them differently and to isolate them from vibrations. The expected benefit of this installation change was described as follows: *"The installation position change including vibration isolators aims to prevent the early failures of the ODS sensors and the occurrence of BLEED 1(2) LEAK messages due to vibration levels present on the pylon tip."*

This SB was implemented on aircraft HB-JVN on 8 December 2015.

⁴ AOM: aircraft operating manual

⁵ MEL: minimum equipment list. In this list, the aircraft manufacturer describes which criteria are valid and which additional procedures must be conducted if certain systems are not available for a flight.

Findings

As described in the prehistory, the BLEED 2 FAIL warning was displayed after the right engine was started. Since a reset according to the checklist was not successful, the maintenance company inspected the right engine pressure regulating shut off valve (PRSOV) (see Figure 1, valve circled in red) after the aircraft landed in Zurich. This revealed that the valve was jammed in the closed position. The PRSOV was then replaced and subjected to a function check, which indicated that the fault had been remedied.

As the BLEED 1 LEAK warning had been displayed during the descent into Zurich, the maintenance company conducted various checks. A leak test in accordance with the aircraft manufacturer's instructions also proved inconclusive. No leak could be found and the warning could not be reproduced using either engine bleed air or APU bleed air. In the present case, the bleed air demand was high, as both engine and wing anti-ice systems were activated. The only bleed air source available was the left engine, which was at flight idle. For this reason, the maintenance company initially concluded, together with the manufacturer, that this high bleed air demand had been met by a high proportion of the hot 9th-stage HP bleed air, which led to the triggering of the BLEED 1 LEAK warning in the vicinity of the pre-cooler and pylon.

The BLEED 1(2) LEAK warning is triggered by sensors in the event of overtemperature in the vicinity of the bleed air ducts. However, as the leak test conducted did not reveal any leak, the maintenance company, after consultation with the aircraft manufacturer, conducted two further investigations in the night from 25 - 26 January 2017.

The first consisted of checking the ODS sensors and was conducted in accordance with the aircraft manufacturer's Service News Letter (SNL) 190-36-0022R00. It involved checking the temperature sensors' positions and mounting clamps. This check did not reveal any negative results.

The second check consisted of checking the pre-cooler outlet duct seal (see Figure 1) in accordance with SNL 190-36-0021R02. This check revealed that the pre-cooler outlet grill (see Figure 2) exhibited small cracks and that the duct seal had become loose. This would only be visible from inside the pre-cooler and could therefore not be seen during the first check which was performed.

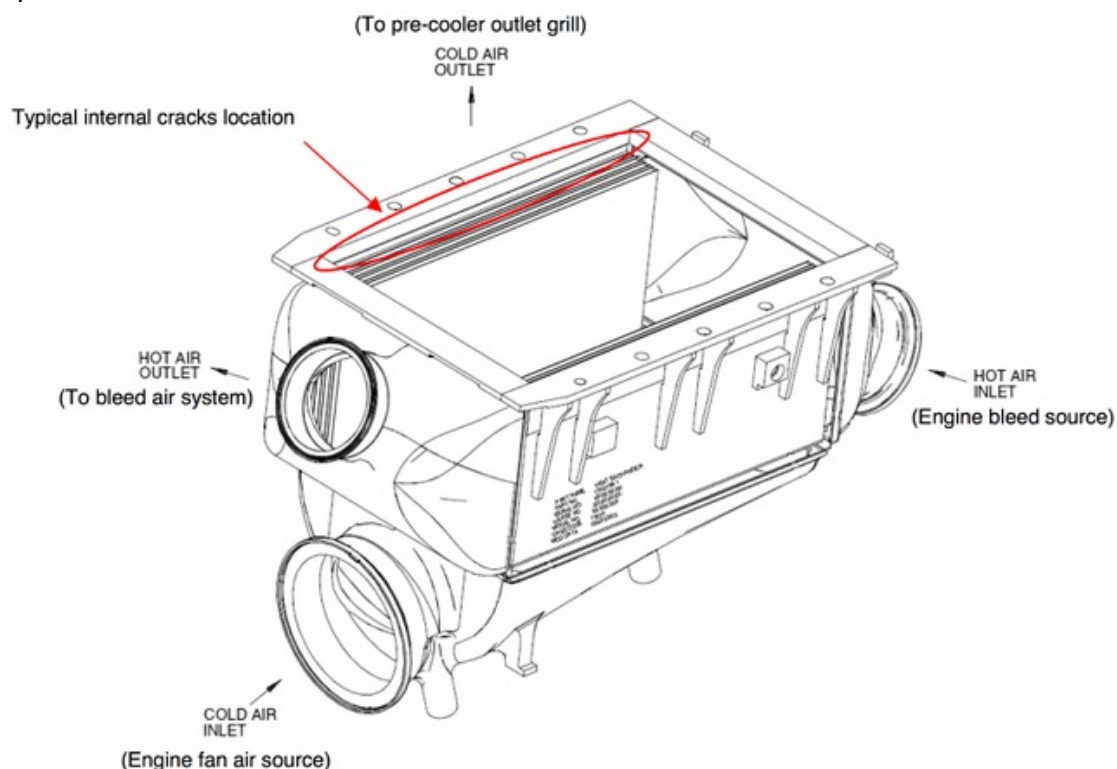

Figure 2: Pre-cooler (Source: SNL 190-36-0021R0)

At the Embraer Operators Conference (EOC) in 2015, the aircraft manufacturer drew the attention of the operators of its aircraft to this problem with information including the following image. The manufacturer also provided the following written information: “Precooler exhaust duct seal damage in aircraft post-mod precooler grill PN 191-08757-401 leading to real leakage.”

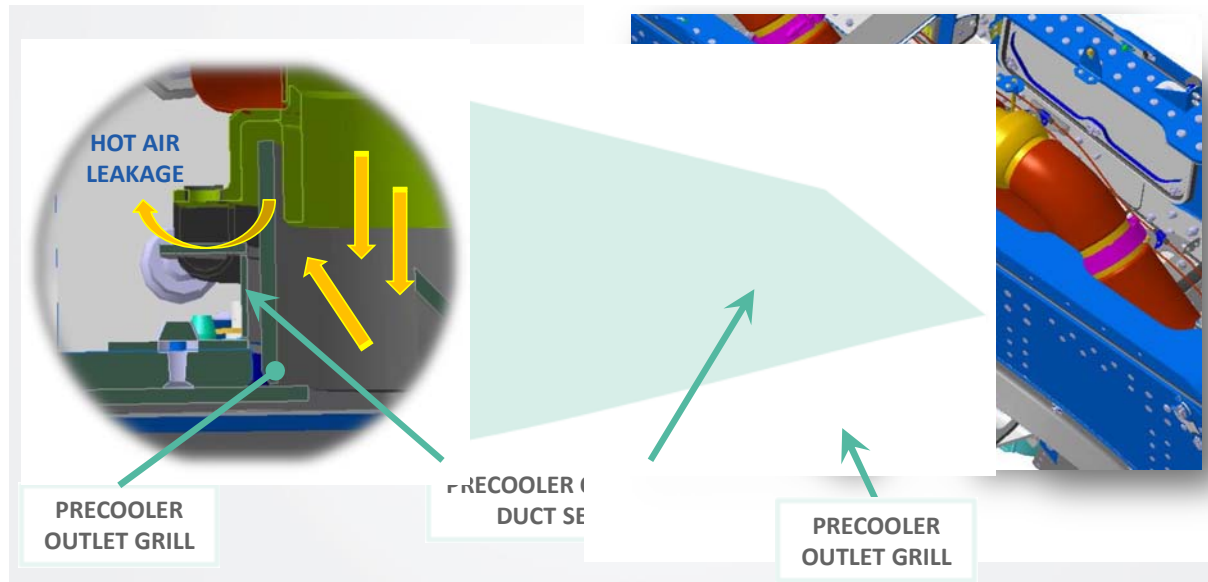

Figure 3: Schematic representation of the pre-cooler outlet duct and pylon grill (Source: EOC 2015)

A post-mod pre-cooler grill, Part Number (PN) 191-08757-401, was installed on aircraft HB-JVN. This was replaced as a result of the findings of the check results. Together with the aircraft manufacturer, the maintenance company came to the unambiguous conclusion that the pre-cooler leak discovered had triggered the BLEED 1 LEAK warning.

Technical analysis and conclusions

A faulty pre-cooler seal allowed hot bleed air to escape. This activated one of the ODS over-heat detection sensors at 07:33:02 UTC. The BLEED 1 LEAK warning message was then generated and the engine 1 bleed air valve was closed. The checklist that the flight crew processed eight minutes later did not change the valve position, but confirmed the shutdown conducted by the automatic system and caused the amber striped bar on the push button to go out. The same checklist requires the crossbleed valve to be closed. The fact that this only occurred eight minutes after the warning appeared was inconsequential in the present case, since the crossbleed valve had automatically been closed as well and no bleed air was available anyway.

The aircraft was descending and the engine power was at flight idle when the ice detectors indicated ice formation at 07:30:29 UTC. As a result, the ICE CONDITION advisory message was displayed on the flight deck and the wing anti-ice valves were opened. The difference between the required and available bleed air became so great that the AMS automatically shut off PACK 2. At 07:31:25 UTC the ice detectors ceased indicating ice formation. However, as the valves remain open for 5 minutes after ice formation ceases to be indicated (see the short description of the system), they were still open when the BLEED 1 LEAK message was displayed and the engine 1 bleed valve closed at 07:33:02 UTC. As no bleed air was available, closing the WAIVs and the resulting A-I WING FAIL warning message was a logical consequence. This meant that the wings could not be anti-iced when the ice detectors indicated renewed ice formation between 07:33:17 UTC and 07:34:09 UTC. However, the engine anti-ice system was still operational as it was supplied directly with 5th-stage LP bleed air.

Operational analysis and conclusions

By consulting the MEL and contacting the maintenance company, the flight crew reacted in a manner appropriate to the situation and in the spirit of the aviation operator. However, if a flight is conducted in accordance with the MEL, it is important to be aware of the fact that the lack of redundancy means a single failure can lead to complete failure of key systems (the cabin air conditioning and pressurization system and wing anti-ice system in the present case). The following information in the MEL: *“The first dispatch condition on MEL has no icing condition restrictions, since the Cross Bleed Valve operates normally”*, may have contributed to the fact that the crew was not sufficiently aware of this.

The fundamental nature of the MEL is that it only mentions the conditions that must be fulfilled in order for a flight to be conducted despite component failures. The decision to conduct a flight in accordance with the MEL, however, is dependent upon other factors, e.g. the weather and other possible technical failures. These can have serious consequences on a flight conducted according to the MEL where the redundancy is already reduced. The decision to execute such a flight is always the responsibility of the commander.

The flight crew reacted to the BLEED 1 LEAK warning message quickly and in a manner appropriate to the situation by immediately requesting a rapid descent and transmitting the urgency message *“Pan, Pan”*. When the A-I WING FAIL warning message was displayed less than a minute later, the flight crew realized that they also could no longer effect wing anti-icing. The immediate decision to vacate icing conditions as rapidly as possible and to declare an emergency, was appropriate to the situation and safety-conscious.

The conversations recorded by the cockpit voice recorder indicate that the flight crew monitored the cabin pressure altitude for the duration of the descent and that this information was used in their considerations. It was for this reason that the flight crew initiated a rapid descent rather than an emergency descent. This is evidence that the crew were in control of the situation and acted with foresight. The cabin pressure reached a maximum pressure altitude of 5500 ft.

Bern, 12 September 2017

Swiss Transportation Safety Investigation Board